

# OPERATION MANUAL

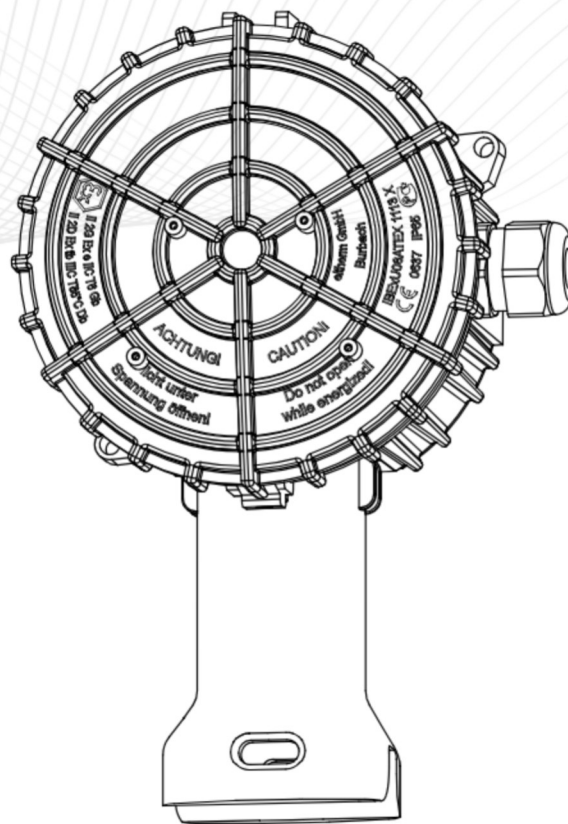

## Ex-It-R INSTALLATION & OPERATION

# CONTENT

TOPIC	PAGE
<b>DESCRIPTION &amp; TECHNICAL DATA</b>	<b>4</b>
DESCRIPTION	4
MODELL VIEWS	4
EXPLOSION PROTECTION	4
CERTIFICATION	4
STANDARDS	4
MARKING	4
TEST STANDARDS	4
TECHNICAL DATA	5
MODELLS	5
Ex-It-R (0X80070)	5
Ex-It-R-T (0X80082)	6
Ex-It-R ELTf (0X80092)	6
<b>INSTALLATION</b>	<b>7</b>
SAFETY INSTRUCTIONS	7
RECEIPT OF THE GOODS	7
STORAGE	7
RECOMMENDED TOOLS	7
REQUIRED WRENCH SIZES	7
ASSEMBLY INSTRUCTIONS	7
MOUNTING ON THE PIPE	8
OPENING THE ENCLOSURE	9
FASTEN THE ENCLOSURE	9
CONNECT THE TRACE HEATER / PT 100	9
CLOSE THE ENCLOSURE	9
CHECK AFTER INSTALLATION	10
OPERATION & MAINTENANCE	10



You can also find this document on the eltherm website.  
Please visit our download area.

## IMPORTANT INFORMATION FOR STORAGE



For proper and safe use of the ELAK-Ex-R connection boxes, please follow these instructions. Please keep these instructions for future reference (e.g. in the system documentation).

## IMPORTANT DISPOSAL INFORMATION



The WEEE logo indicates that this product should not be disposed of with other waste. For more information on the disposal and recovery of waste electrical and electronic equipment (WEEE) and collection points, please contact your local waste disposal company or the manufacturer from whom you purchased the product.



### ATTENTION

Refers to a potentially dangerous situation. If it is not prevented, there is a risk of danger or malfunction.



### DANGER

Refers to an extremely dangerous situation. If it is not prevented there is risk of death or at least a high risk of serious injuries.



### NOTE

Important information and instructions for safe, effective and environmentally compatible usage.



### WARNING

Refers to a dangerous situation. If it is not prevented there is risk of injury or at least a high risk of material damage.

## Proviso

We reserve the right to make technical changes. Changes, errors or misprints shall not form the basis for any claim to compensation for damages. Comply with the applicable and currently valid standards and regulations for safety-related components and systems.

eltherm GmbH Ernst-Heinkel-Str. 6-10 57299 Burbach T.: +49 2736 4413-0 F.: +49 2736 4413-50 info@eltherm.com	Document: 8643040X800XX Operation Manual Ex-it-R (BU-139) EN		Operation Manual Ex-it-R	
	Autor:	Detlef Matthes	Datum:	12.05.2023
	Revision: 0		Datum:	



**TECHNICAL DATA**

Operating voltage (max.)	800 V AC
Rated current	max 32 A each terminal 6 mm <sup>2</sup> (Ex-It-R-ELTf max. 24 A)
Ambient temperature	- 20 °C bis +50 °C
Nominal cross-section*	Power cable max. 10 mm <sup>2</sup> , Ø 9 - 17 mm
Junction box material	Polyamid, glass fiber reinforced, black
Dimensions	(ca.) Ø 154,5 mm, Height 266 mm, Depth 125 mm
Protection class	IP 65
Operating temperature mounting stand	max. +200 °C
Material mounting stand	PPS (Cable entries: 3 x flat heater; 1 x sensor cable)
Possible cable dimensions	Ø 3 – 5 mm; 4 x 11 mm – 5,5 x 14 mm
Possible jacket materials	TPE min. 0,7 mm; Fluoropolymer min. 0,4 mm
max. insulation thickness	100 mm
min. Tube diameter	≥ NW3/4" / OD 20 mm (max. width of tightening strap: 16 mm)
Weight	approx. 1.2 kg

\* Connection cross-section (solid or fine-stranded without wire end sleeve); terminals heating cable max. 6 mm<sup>2</sup> (AWG10); Terminals temperature sensor max. 2.5 mm<sup>2</sup> (AWG 13)

**! DANGER**

**SPECIAL CONDITIONS according to Type Ex certificate**

The ambient temperature range, depending on the cable glands used, is specified from -45°C or -40°C (Type R. steel 8161/5 & steel 8161/6) to +50°C.

**MODELLS**

**Ex-It-R (OX80070)**

Junction box incl. mounting base, for up to 3 ELSR-N/-H, 1 connection line, 1 sensor line

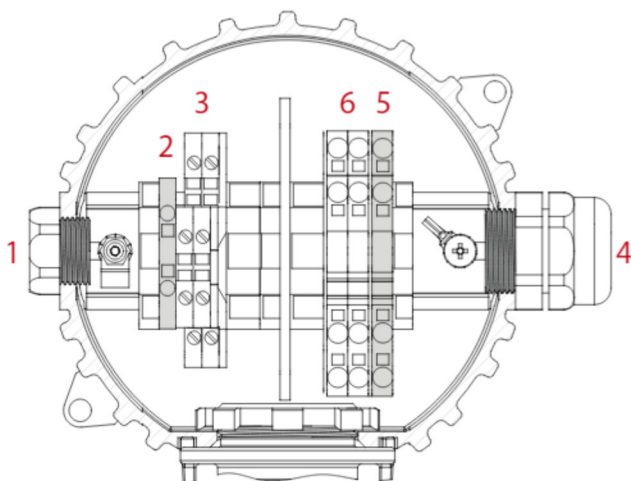

Nº.	Type	pcs	Clamp range
1	Blind plug M20x1,5	1	-
2	Protective conductor terminal	1	2,5 mm <sup>2</sup>
3	Double-level terminal	2	2,5 mm <sup>2</sup>
4	Cable gland M25x1,5	2	9-13/12-17 mm
5	Protective conductor terminal	2	4 mm <sup>2</sup>
6	4 conductor through terminal	2	4 mm <sup>2</sup>

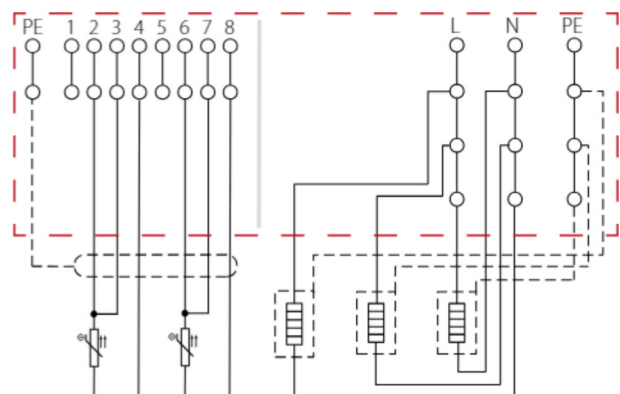

■ Terminal for earthing or electrical protection

**Ex-It-R-T (0X80082)**

Junction box incl. mounting base, for splice or T-connection, up to 3 ELSR-N/-LS/-H/-SH/-SHH

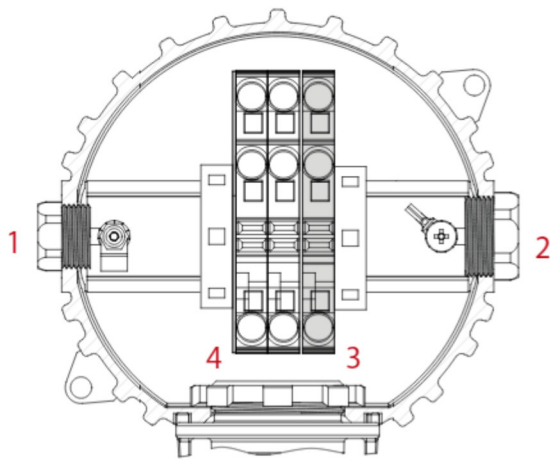

Nº.	Type	pcs	Clamp range
1	Blind plug M20x1,5	1	-
2	Blind plug M25x1,5	1	-
3	Protective conductor terminal	1	10 mm <sup>2</sup>
4	3 conductor through terminal	2	10 mm <sup>2</sup>

■ Terminal for earthing or electrical protection

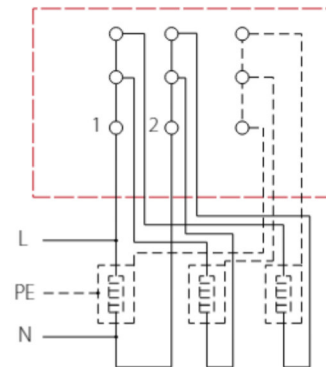

**Ex-It-R-ELTf (0X80092)**

Junction box incl. mounting base, 1 PT100 or 1 double PT100

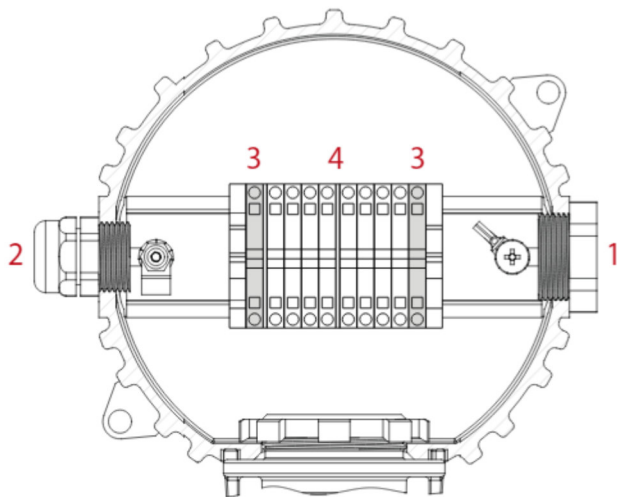

Nº.	Type	pcs	Clamp range
1	Blind plug M25x1,5	1	-
2	Cable gland M20x1,5	1	9 - 12 mm
3	Protective conductor terminal	2	2,5 mm <sup>2</sup>
4	Feed through-terminal	8	2,5 mm <sup>2</sup>

■ Terminal for earthing or electrical protection

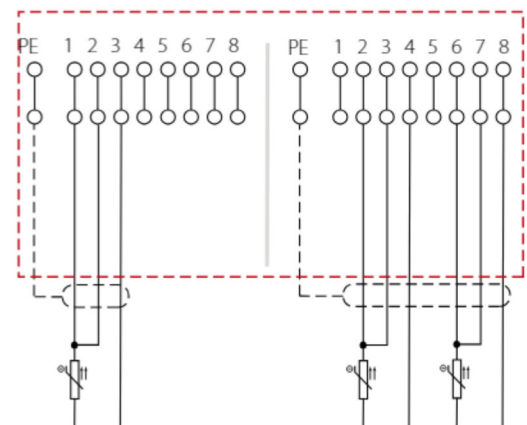

# INSTALLATION

## SAFETY INSTRUCTIONS

### **ATTENTION**

- The following steps should only be carried out by persons trained in handling explosive equipment.
- Strict compliance with the relevant safety regulations in potentially explosive atmospheres is a requirement for the safety of persons, plants and equipment.
- The persons entrusted with the planning, installation and maintenance bear a special responsibility and must therefore be thoroughly familiar with the applicable regulations.
- These instructions are intended for this group of people and contain all the important information required for the safe handling of the ELAK-Ex-R junction boxes.
- The instructions must be kept together with the system documentation for later use and must be kept and be available during the entire service life of the product.

## RECEIPT OF THE GOODS

On receipt of the goods, check the junction boxes and the accessories and compare the type information with the information on the delivery note to ensure that the correct material has been delivered.

## STORAGE

Storage should be in a dry, clean place at an ambient temperature from 0°C to 50°C.

## RECOMMENDED TOOLS

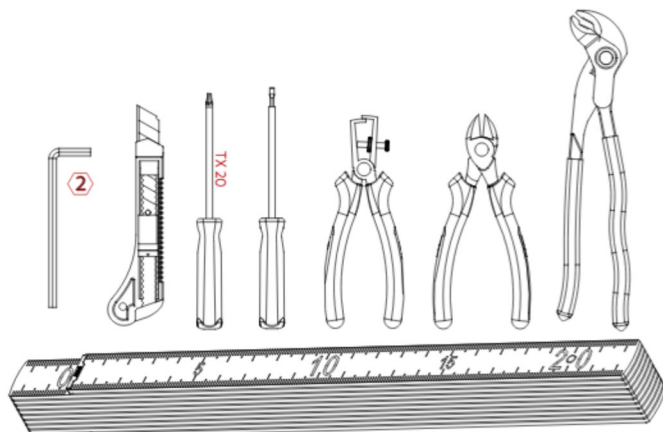

## REQUIRED WRENCH SIZES

Size	Clamping range	Wrench size	Torques	
			Thread	Screw
	[mm]	[mm]	[Nm]	
M20	5,5 - 13	24	3,75	3,5 - 2,5
M25	8 - 17	29	5	5 - 3

## ASSEMBLY INSTRUCTIONS

### **ATTENTION**

- When selecting the mounting location, take into account the degree of mechanical danger to the junction box and the cable entries as well as the permissible ambient temperature.
- Ensure that the surface on which the junction box is mounted is capable of bearing loads.
- Cables inserted into the junction box must be laid firmly and secured against being pulled out of the cable entry (e.g. by a cable clamp).
- Unused clamping points must be tightened.
- All cable entries, reducers and blind plugs may only be used in conjunction with threaded connection seals, O-rings or moulded sealing elements and must be separately tested and approved for type of protection „e“ or „t“ with EPL Gb or Db.
- Seals in the cable entries must not be exchanged or nested.
- Threaded boreholes can be reduced in size. However, several reducers must not be reductions must not be nested.
- Before inserting blind plugs, reducers or conduit entries into free threaded boreholes, make sure that the threaded borehole is clean and undamaged and that the respective threads fit together.
- After connection, all openings must be closed tightly (cover, threaded boreholes, cable entries). Use suitable open-end, ring or socket spanners to tighten the cable entries. The torques (see before) must be observed.
- **ATTENTION:** Excessive tightening may impair the IP protection class!
- The lid of the junction box is designed to mount a identification plate provided by the customer. Use screws Ø 2.2 x 6 mm for fastening.

## MOUNTING ON THE PIPE

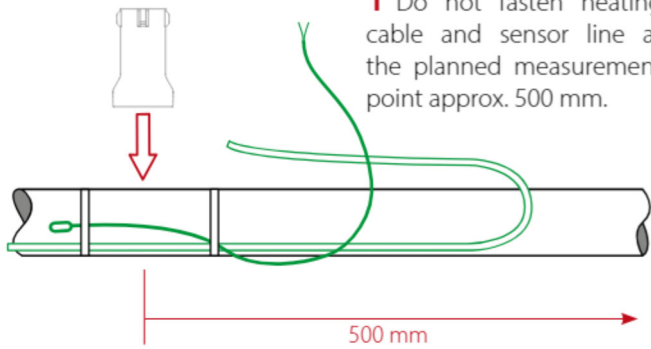

**2** Prepare the end of the sensor line with a strong wire and by using adhesive tape to lead a sensor line into the mounting base.

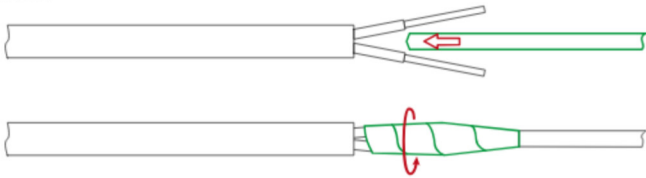

**3** Lead a sensor line into the opening provided and pull it about 200 mm into the mounting base.

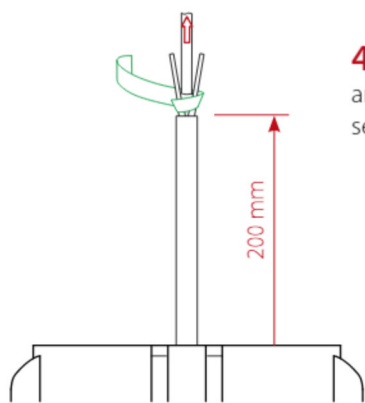
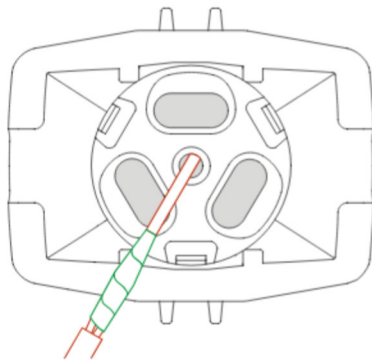

**4** Remove the adhesive tape and strong wire from the sensor line.

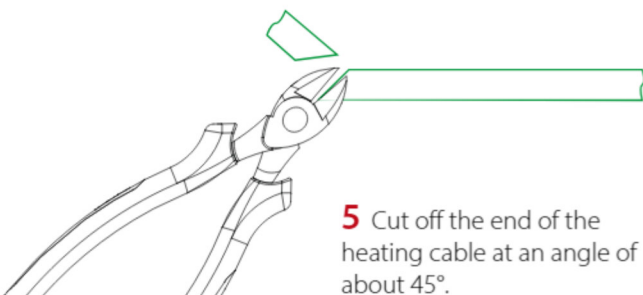

**6** Guide the heating cable into the mounting stand.

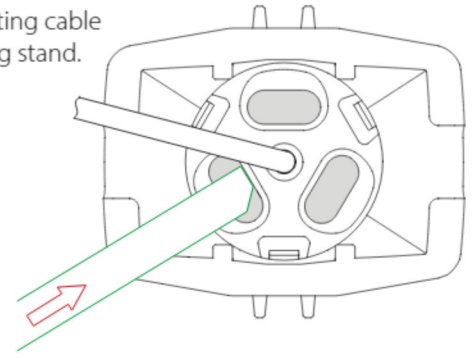

**7** Guide the heating cable about 200 mm through the mounting stand.

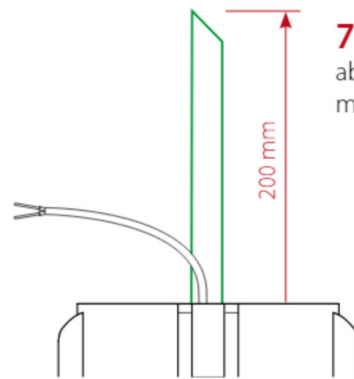

**8** Fasten the mounting stand onto the pipe with a strap. Do not feed tightening strap above heating cable or sensor cable!

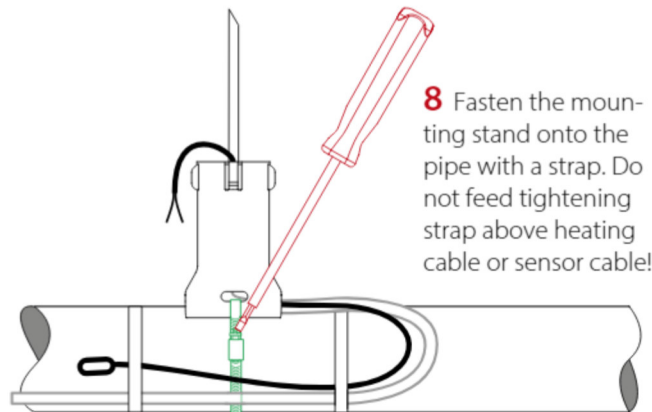

**9** Mount the heating cable connection (not included with delivery).

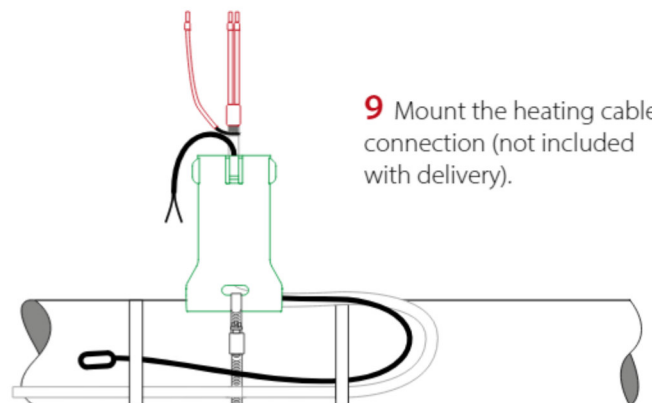

### OPENING THE ENCLOSURE

**10** Tighten the headless screw with an Allen wrench (size 2) until the locking arm is flush with the side bars

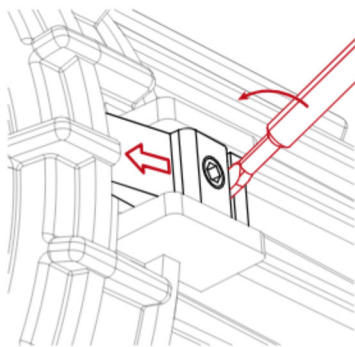
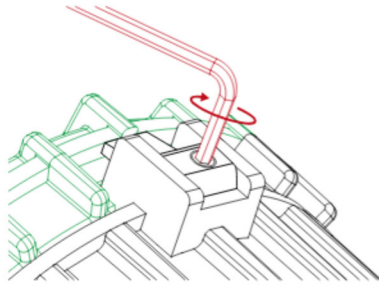

**11** Insert a flat-tip screwdriver between the locking arm and the rear bar and push the locking arm forward a few millimetres by turning the screwdriver.

**12** Turn the headless screw back with the Allen wrench (size 2) until it is protruding slightly out of the locking arm.

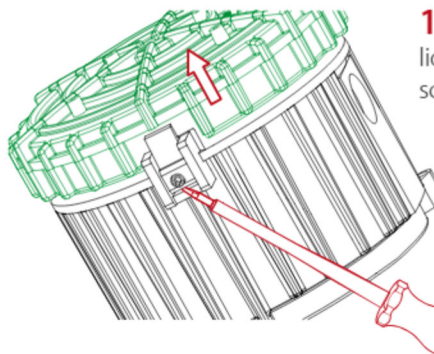
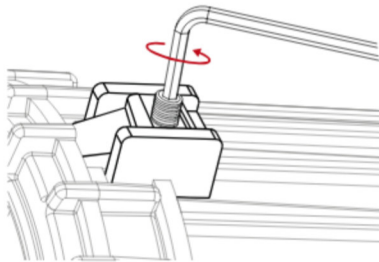

**13** Lift the lid (using the screwdriver)

**14** Open the lid (using the screwdriver)

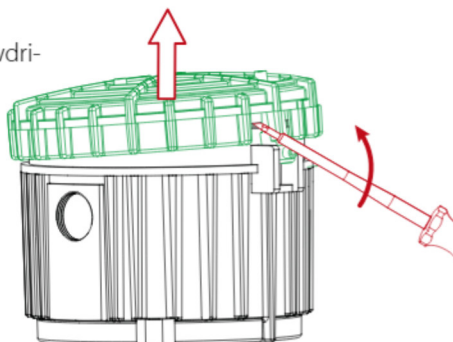

### FASTEN THE ENCLOSURE

**15** Attach the housing to the Ex-it mounting stand. The housing must engage clearly audibly (2x click).

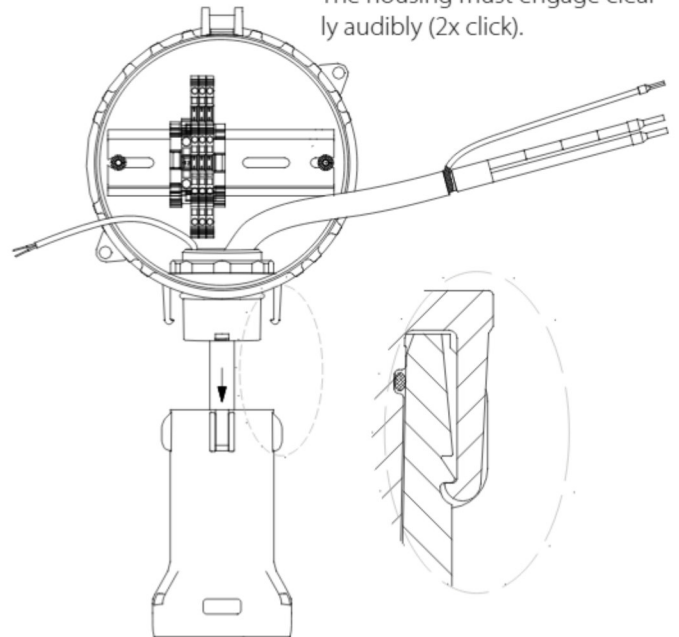

### CONNECT THE TRACE HEATER / PT 100

#### **ATTENTION**

- Please observe the respective installation instructions for the heating cables / sensors to be connected.
- Make sure that all terminals and cable glands are tightened according to the instructions.
- Before closing the terminal box, carry out the installation check of the heating cables.

### CLOSE THE ENCLOSURE

**16** Visual inspection of housing and cover to ensure they are not damaged. Cover can only be inserted in one position (locking arms / twist protection recesses have different width). Move the cover to the appropriate position.

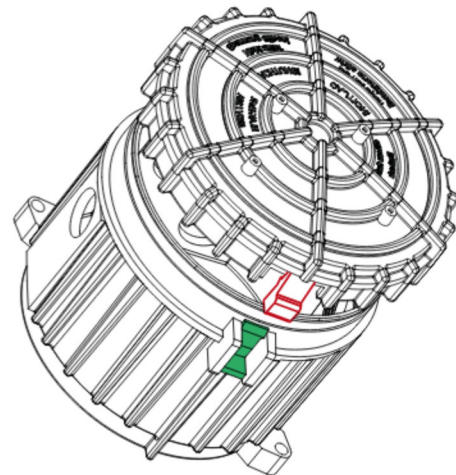

**17** Attach the cover with the narrower locking arm (without a headless screw), close the cover and...

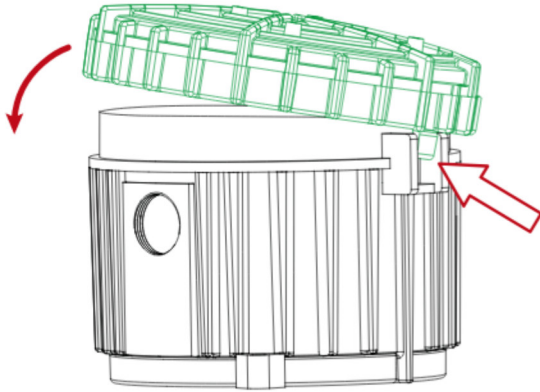

**18** Use the pliers to lock the cover

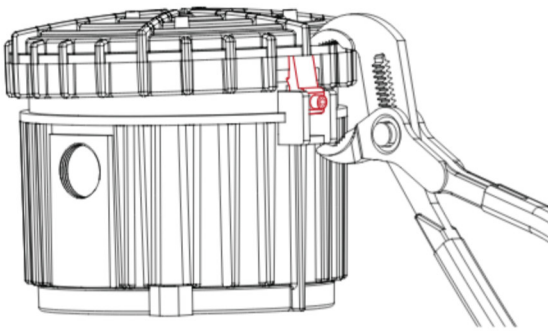

## CHECK AFTER INSTALLATION

### **ATTENTION**

After completing the installation, the following steps must be taken:

- Visual inspection of the junction boxes for possible mechanical damage.
- Damaged junction boxes must not be put into operation and must be replaced.
- Check the cover of the junction box and its attachments (cable entries) for tight fit.
- All threaded openings must be fitted with cable entries or blind plugs, which must be firmly tightened and tight.

## OPERATION & MAINTENANCE

### **DANGER**

- The junction boxes may only be opened (this also includes loosening cable entries!) in a de-energised state, disconnected from the power supply.
- Damaged junction boxes must not be put into operation.

### **ATTENTION**

- When operating the junction boxes, the permissible ambient temperature must be observed.
- The locally applicable safety regulations must be observed.
- The permissible operating conditions according to „Technical data“ or labelling (voltage, current, operating temperature, maximum ambient temperature, IP protection class) must be observed.
- The cable entries must not be operated in dust explosion hazardous areas with dust deposits  $\geq 50$  mm.
- It is recommended to visually check the integrity and tight fit of the cable gland and the connected cable at suitable intervals depending on the installation location and application.
- If necessary, the cable entries must be retightened, damaged junction boxes or cable entries must be replaced by qualified personnel.
- If repair work is to be carried out on heated system parts, the junction boxes must be protected against damage.
- After completion of the repair work, the junction box must be checked again.

**eltherm**<sup>®</sup> 

**eltherm GmbH  
Headquarters**

Ernst-Heinkel-Straße 6-10  
57299 Burbach, Germany

T.: +49 2736 4413-0

F.: +49 2736 4413-50

info@eltherm.com